



Learning motivation mediates gene-by-socioeconomic status interaction on mathematics achievement in early childhood

Elliot M. Tucker-Drob^{*}, K. Paige Harden

Department of Psychology and Population Research Center, University of Texas at Austin, United States

ARTICLE INFO

Article history:

Received 11 July 2011

Received in revised form 12 October 2011

Accepted 22 November 2011

Keywords:

Gene-by-environment interaction

Academic achievement

Socioeconomic status

Behavioral genetics

ABSTRACT

There is accumulating evidence that genetic influences on achievement are more pronounced among children living in higher socioeconomic status homes, and that these gene-by-environment interactions occur prior to children's entry into formal schooling. We hypothesized that one pathway through which socioeconomic status promotes genetic influences on early achievement is by facilitating the processes by which children select, evoke, and attend to learning experiences that are consistent with genetically influenced individual differences in their motivation to learn. We examined this hypothesis in a nationally representative sample of approximately 650 pairs of four-year old identical and fraternal twins who were administered a measure of math achievement, and rated by their parents on a broad set of items assessing learning motivation. Results indicated a genetic link between learning motivation and math achievement that varied positively with family socioeconomic status: Genetic differences in learning motivation contributed to math achievement more strongly in more advantaged homes. Once this effect of learning motivation was controlled for, gene-by-socioeconomic status interaction on math achievement was reduced from previously significant levels, to nonsignificant levels.

© 2011 Elsevier Inc. All rights reserved.

Family socioeconomic status (SES) is consistently associated with higher cognitive performance and academic achievement throughout childhood and adolescence (Sirin, 2005; White, 1982). In fact, SES-related differences in cognition and achievement are apparent before children even begin formal education (Heckman, 2006; Magnuson, Meyers, Ruhm, & Waldfogel, 2004; Tucker-Drob, Rhemtulla, Harden, Turkheimer, & Fask, 2011). This is particularly noteworthy, because SES-related disparities in academic achievement are often perceived as stemming from differences in the quality of educational experiences during the school years. While differences in school quality may indeed serve to perpetuate, if not exacerbate, SES-related differences in achievement, such differences cannot plausibly explain the SES-related disparities that are evident prior to school entry. Moreover, because achievement prior to kindergarten entry (i.e. school readiness) has been prospectively linked with sustained academic achievement throughout the school years (Duncan et al., 2007), early SES-related disparities in school readiness are likely to be quite consequential for later periods of development.

Perhaps the most intuitive explanation for the emergence of SES-related differences in early academic achievement is that SES represents differences in the quality of early environmental inputs that have direct causal effects on learning. Consistent with this interpretation, many studies have found that children growing up in lower-SES homes tend to receive less verbal stimulation and have fewer educational resources at

their disposal, among many other relative deprivations (Bradley, Corwyn, McAdoo, & Coll, 2001; Garrett, Ng'andu, & Ferron, 1994). Moreover, findings from adoption studies (e.g. Capron & Duyme, 1989) and studies of children rescued from severe poverty (e.g. Nelson et al., 2007) have indicated large causal effects of environmental context on cognition and achievement. Direct causal explanations, however, have been historically difficult to reconcile with findings from twin and adoption studies that suggest that genes account for substantial proportions of individual differences in cognition and achievement (Bouchard & McGue, 2003). As Dickens and Flynn (2001) have commented, "We know that potent environmental factors exist; [the classical behavioral genetic] analysis suggests that they should not exist. How can this paradox be resolved?"

1. Gene-environment interactions in achievement and cognitive development

One theoretical proposition that may help to resolve the apparent paradox of large heritability estimates and large environmental effects holds that one pathway by which socioeconomic opportunity affects cognitive development is by facilitating the expression of genetic differences – a gene-environment interaction. Supporting this proposition, emerging research in behavioral genetics indicates that heritable variation in cognition and achievement is larger among children growing up in higher SES contexts. For instance, Turkheimer, Haley, Waldron, D'Onofrio, and Gottesman (2003) found that the heritability of IQ of 10% for 7-year old twins living in low-SES families but was 72% among 7-year old twins living in high-SES families. Rowe, Jacobson, and Van den Oord (1999) reported congruent findings for verbal ability in a

^{*} Corresponding author at: Department of Psychology, University of Texas at Austin, 1 University Station A8000, Austin, TX 78712–0187, United States. Tel.: +1 512 232 4225. E-mail address: tuckerdrob@psy.utexas.edu (E.M. Tucker-Drob).

nationally-representative sample of high school students: among students from the least educated families, heritability of verbal ability was 26%, whereas this estimate was 72% for students from the most educated families. Harden, Turkheimer, and Loehlin (2007) reported a similar interaction between genes and parental income on academic achievement in a sample of 17-year olds.

While the original reports of gene-by-SES effects were based on school-aged samples, such effects are also evident in very young children prior to school entry. Tucker-Drob, Rhemtulla, Harden, Turkheimer, and Fask (2011) found that gene-by-SES effects on mental ability emerged over early childhood. At 10 months of age, genes accounted for negligible variation in mental ability regardless of SES, whereas by 2 years of age, genes accounted for nearly 50% of the variation in mental ability among high SES children, but continued to account for negligible variation in mental ability among low SES children. Concomitant with the emergence of these SES differences in heritability was the emergence of SES differences in average mental ability scores. In a follow-up study of the same cohort of twins, Rhemtulla and Tucker-Drob (submitted for publication) found evidence for gene-by-SES effects on early mathematics skills among 4 year olds. At 2 SDs below the mean on SES, genes accounted for 0% of the variance in math scores, and at 2 SDs above the mean on SES, genes accounted for 42% of the variance in math scores. Taylor and colleagues have reported similar associations between neighborhood income (sometimes referred to as neighborhood SES) and the heritability of literacy in first grade twins (Taylor & Schatschneider, 2010), and classroom quality (a consistent correlate of school SES) and the heritability of reading skills in first and second grade twins (Taylor, Roehrig, Hensler, Connor, & Schatschneider, 2010). Thus, multiple research groups have found, using independent samples spanning from 2- to 17-years olds, that genetic variation in cognitive ability and academic achievement is maximized under conditions of socioeconomic advantage.

2. Non-cognitive traits as mechanisms of gene-environment interaction in achievement

While accumulating evidence suggests that socioeconomic status interacts with genetic influences on early achievement, an important next step will be to more specifically delineate *how* genetic influences on achievement come to be maximized by socioeconomic advantage. One possible mechanism involves children's non-cognitive traits that lead them to interact differentially with their proximal environments. In the current paper, we use the term *learning motivation* to refer to the constellation of noncognitive traits that we conceptualize as central to this process. These are "inclinations, dispositions, or styles rather than skills that reflect the myriad ways that children become involved in learning, and develop their inclinations to pursue it" (Kagan, Moore, & Bredekamp, 1995). There are multiple processes by which high levels of learning motivation may drive early cognitive development *when given adequate environmental opportunities*. First, higher motivation to learn may lead to increased exposure to cognitively stimulating experiences and interactions (Scarr & McCartney, 1983), either because the child actively seeks such experiences or because the child more successfully evokes these experiences from caregivers and teachers. For instance, a young child who responds positively to verbal stimulation from a parent might be spoken to more, or a young child who displays an interest in and engagement with educational toys might receive more such toys as gifts. Second, learning motivation can lead to increased cognitive benefits from stimulating experiences (Cattell, 1987); the motivated child may attend to educational experiences more closely or put more effort into succeeding at them. For instance, two children who are observing the exact same educational video, or playing with the exact same educational toy, might invest different levels of passive attention or active effort in each of the respective tasks.

Moreover, because all of these processes involve the interface between the child and his or her proximal physical, social, and educational environments, these processes are likely to vary across macro-environments that differ in opportunity for enriching interactions with proximal environments. In addition to the direct effects of economic privation on cognition and achievement, socioeconomic disadvantage is also associated with fewer opportunities for intellectually stimulating interactions between children and their proximal environments (Bronfenbrenner & Ceci, 1994). For example, parents and educators are, on average, less responsive to children from low SES backgrounds (De Wolff & van Ijzendoorn, 1997). Consequently, these differences in opportunity may produce differences in the extent to which highly motivated children are able to translate their non-cognitive traits into higher cognitive skills.

More specifically, it is the link between achievement and the *genetically influenced* components of motivation that is most likely to be affected by socioeconomic opportunity. Even in the context of high opportunity environments, in order to have meaningful effects on children's learning and development, motivational factors need to act in consistent and recurring ways over extended periods of time: It is not enough for a child to be motivated to engage in stimulating play with a caregiver on one day, if the next day the child is unmotivated to engage in such play. Rather, in order for motivational factors to have meaningful and lasting effects on learning, the child will need to establish a long term pattern of motivated approaches towards learning that aggregate over time and reinforce previous cognitive gains (Dickens & Flynn, 2001; also see Dickens, Turkheimer, & Beam, 2011). It is well established that it is the genetic aspects of behavioral patterns that tend to be persistent and recurring over development, whereas nonshared-environmentally influenced traits are more likely to be ephemeral "one time" events that do not consistently recur (Caspi, Roberts, & Shiner, 2005). Because it is genetic components of traits that are likely to be highly stable over development, it is genetic variance in motivation that compounds systematically over time. Based on this rationale, we predict that it is the coupling between achievement and genetic differences in learning motivation (along with related non-cognitive factors) that is amplified among children raised in higher SES contexts, and suppressed among children raised in lower-SES contexts.

Previous work (Tucker-Drob & Harden, *in press-a*), which used data from a sample of adolescent twins, found evidence that genetic variance in non-cognitive traits was more strongly coupled with academic achievement in teenagers from higher SES homes. Specifically, heritable variation in intellectual interest was more strongly associated with academic achievement among adolescents being raised in higher SES families, resulting in higher levels of heritability of achievement among those adolescents. Because this research focused on adolescents, it is straightforward to infer that intellectual interest resulted in individuals being exposed to more stimulating and challenging environmental experience via an *active* process of selection. Particularly in advantaged contexts, teenagers have great latitude to select their own coursework, peer groups, and extracurricular activities in accordance with their own individual interest levels.

However, it is unclear whether SES would moderate the relation between noncognitive traits and achievement in young children, who have relatively very little autonomy in making active decisions about their experiences. As discussed above, non-cognitive traits could lead to differential exposure to environmental experiences without active selection. More interested or motivated children may *evoke* different experiences from their caregivers, and may selectively direct efforts towards attending to and engaging in educational experiences, when these experiences are available — as is more likely to be the case in high opportunity macro-environmental contexts. Therefore, we expect that the association between genetic variation in motivation and achievement might be similarly positively moderated by SES, even during the preschool years. To test this hypothesis, the current study

uses the same sample of 4-year old twins to test (1) whether the relation between genetic variance in motivation and math achievement is positively moderated by family SES, and (2) whether this de-coupling of motivation and achievement in lower-SES homes accounts for the gene-by-SES interaction previously observed in this dataset (Rhemtulla & Tucker-Drob, submitted for publication).

3. Method

3.1. Participants

The current project used data on approximately 650 pairs of identical and fraternal twins¹ from the Early Childhood Longitudinal Study-Birth Cohort (ECLS-B), a population-based study of approximately 14,000 children born in the United States in 2001. ECLS-B is representative of the United States population in socioeconomic and racial/ethnic diversity: 61% of the twin pairs were White, 16% were African-American, 16% were Hispanic, 2% were Asian, 1% were Pacific Islander, American Indian, or Alaska Native, 4% were of mixed race, 49% were male, and 24% lived below the poverty line at study entry. The current project is based on measures of motivation and mathematics achievement that were taken when the children were approximately 4 years old. Ratings of motivation were available for 95% of twins, and math test scores were available for 86% of twins.

3.2. Measures

3.2.1. Zygosity

Zygosity of same-sex twin pairs was diagnosed using physical similarity ratings of hair color, hair texture, complexion, facial appearance, and ear lobe shape, made by trained observers from the ECLS staff when the twins were approximately 2 years old. Similarity rating were coded as 1 (“no difference”), 2 (“slight difference”) or 3 (“clear difference”). Following the procedure described in Tucker-Drob et al. (2011), these ratings were summed across items, resulting a bimodal distribution of scores ranging from 6 to 18. Based on the shape of this distribution, twin pairs scoring in the 6–8 range were diagnosed as monozygotic (MZ), and twin pairs scoring 9 and above along with opposite-sex twins were diagnosed as dizygotic (DZ). Of the complete sample of twins who provided 4-year data, we excluded from analyses the fewer than 50 pairs who met criteria for DZ diagnosis but whose parents indicated that there was a medical reason for their lack of similarity, resulting in a working sample of approximately 650 pairs.

3.2.2. Socioeconomic status

A socioeconomic status (SES) composite score was created by averaging indices of paternal and maternal educational attainment, family income, and paternal and maternal occupational prestige, each of which had been z-transformed relative to the mean and standard deviation observed in the entire sample. So that the current results could be directly compared to those reported in previous work with these data (Rhemtulla & Tucker-Drob, submitted for publication), we used indices obtained in 2003–2004. Note, however, that results were very similar when indices obtained in 2005–2006 were used to form the SES composite (the stability of SES across the two waves was $r = .89$).

3.2.3. Learning motivation

At the 4-year wave, parents reported on each of their twins as individuals. This questionnaire was designed to include items tapping *Approaches Towards Learning*, which are defined as “tendencies,

behaviors, and skills that support a positive attitude about learning” (Najarian, Snow, Lennon, & Kinsey, 2010, p. 153). These items were originally adapted from the Social Skills Rating System (SSRS; Gresham & Elliott, 1990). Parents rated (1 = Never, 2 = Rarely, 3 = Sometimes, 4 = Often, 5 = Very often) the following items: (1) child shows eagerness to learn; (2) child pays attention well; (3) child works/plays independently; and (4) child keeps working until finished. A single common factor fit the item responses well (RMSEA = .068, CFI = .987, TLI = .962, SRMR = .020), with all four items loading significantly on the common factor (standardized loadings were .60, .77, .49, and .62, for items 1–4 respectively). A learning motivation score was therefore formed by taking the average of all four item responses.

3.2.4. Early mathematics achievement

At the 4-year wave, participants were administered a test of mathematics skills that was developed specifically for the ECLS-B (Najarian et al., 2010). This test comprised 45 items tapping the following content areas: number sense, geometry, counting, operations, and patterns. A three parameter logistic item response theory model (one parameter representing item difficulty, one parameter representing item sensitivity, and one parameter accounting for probability of choosing the correct choice by guessing) was applied to responses to these items, which was then used to compute an overall math score for each individual (for details see Najarian et al., 2010).

4. Analyses and results

A series of univariate and bivariate behavioral genetic models were fit using full information maximum likelihood estimation in Mplus statistical software (Muthén & Muthén, 1998–2010). Alpha levels were set to .05. All analyses were conducted in a series of steps. First, we estimated all main effects of SES, genes, and environment, and the interactions of SES with genes and environment. Second, we fit trimmed models in which all interaction parameters that were not statistically significant in the first step were removed. Third, we fit fully reduced models in which the main effect parameters that were not statistically significant in the previous step were removed. Fourth, we compared the fully reduced models estimated in the third step with the complete models estimated in the first step. If the reduced models did not fit significantly worse than the complete models, we accepted the reduced models as the best representations of the data.

5. Univariate analyses

As a first step, we tested for gene-environment interactions on motivation and math achievement separately, using a univariate behavioral genetic model that decomposes between-person variation in a given phenotype, Y , into variation accounted for by genes, the environment, and their interactions with SES (Purcell, 2002). Such a model can be written as:

$$Y_{t,p} = (s \cdot \text{SES}_p) + (a + a' \cdot \text{SES}_p) \cdot A_{t,p} + (c + c' \cdot \text{SES}_p) \cdot C_p + (e + e' \cdot \text{SES}_p) \cdot E_{t,p}, \quad (1)$$

where the subscript p indicates that a term is allowed to vary across twin pairs, and the subscript t indicates that a term is allowed to vary across twins within the same pair. The latent variables A , C , and E are latent variables representative of additive genes, shared (or common) environmental influences that are experienced from both twins from a given pair and serve to make them more similar to one another, and nonshared environmental influences that have uncorrelated effects across twins, respectively. The scales of A , C , and E are defined by fixing their variances to 1. Based on genetic theory, the correlation between the A factors is fixed to 1.0 in MZ twins (who share 100% of their genes), and fixed to .50 in DZ twins (who, on average, share 50% of

¹ All sample sizes are rounded to the nearest 50 in accordance with ECLS-B data-security regulations.

the genes that vary within humans). The coefficients s , a , c , and e , represent the main effects of SES, A, C, and E on the phenotype, and the coefficients a' , c' , and e' , represent the interaction effects of SES with A, C, and E on the phenotype. Note that because SES is measured at the family-level, it is by definition treated as a measure of the shared environment. Controlling for the main effect of SES, therefore, controls for variation that would otherwise be attributed to the shared environment. Nevertheless, it is important to be aware of the fact that, because family SES may be partly determined by genetically influenced characteristics of the parents, which are in turn inherited by the children, SES may represent both environmental and genetic variation.² The application of this model to math achievement is presented as a path diagram in Panel A of Fig. 1. Note that for ease of presentation this figure only represents one twin from each pair.

6. Results of univariate analyses

Parameter estimates from the univariate behavioral genetic models of motivation are presented in Table 1. The full Step 1 model indicated no statistically significant evidence for SES moderation of the magnitude of genetic, shared environmental, or non-shared environmental variance in motivation. Further, in the Step 2 model in which all SES interactions have been removed, the shared environment does not account for a statistically significant amount of variance in motivation. The Step 3 model, in which the main effect of the shared environment and all SES interactions have been removed, fits as well as the full Step 1 model ($\chi^2[4] = 4.69$), and has the most preferred (lowest) AIC and BIC values. It can therefore be accepted as the best representation of the data. In this final model, SES accounts for .04 units of variance (9%) in motivation,³ and of the remaining variation in motivation, .18 units of variance (49%) are accounted for by genes and .20 units of variance (51%) are accounted for by the nonshared environment.

Parameter estimates from the univariate behavioral genetic models of mathematics are presented in Table 2. (These analyses recapitulate some of the results previously presented in Rhemtulla & Tucker-Drob, submitted for publication, and are presented here to highlight the contrast with the univariate results obtained for motivation, described above, and to provide context for the mediation analyses to be described subsequently). In the full Step 1 model, the a' parameter is statistically significant, indicating that the variance in math scores accounted for by genes differs with SES. The c' and e' parameters, however, were not statistically significant, and were removed for the Step 2 model. In this model, all main effect parameters are significant, thus a Step 3 model (removing non-significant main effects) is unnecessary. This final model fit no differently from the full Step 1 model ($\chi^2[2] = 2.50$), indicating that it is the best representation of the data. AIC and BIC values of the Step 2 model are lower than those for the Step 1 model, further supporting the acceptance of the Step 2 model as the preferred representation of the data. In this final model, SES accounts for .18 units of variance (28%) in math scores. Of the remaining variation in math scores, the shared environment accounts for .28 units of variance (60%), the nonshared environment accounts for .10 units of variance (21%), and genes account for an average of .09 units of variance (19%), although this latter figure varies positively with SES. This gene-by-environment interaction is displayed in Fig. 2, which plots SES on the horizontal axis, and the amount of unstandardized variance in math scores accounted for by A, C, and E on the vertical axis: at very low levels of SES, genes account for negligible variance in math scores, whereas at very high levels of SES the amount of variance in math scores accounted for by genes exceeds .30 (45% of the SES-independent variation).

² A more complex research design (e.g. an extended twin-family design, or a children of twins design) would be necessary to partition variation in SES into genetic and environmental components.

³ Amount of variance accounted for by SES = $.195^2$. Percentage of variance accounted for by SES = $(.195^2) / (.195^2 + .429^2 + .442^2)$.

6.1. Bivariate analyses

Next, we examined whether the gene-by-SES interaction found for math achievement could be accounted for by an increased relation between genetic differences in learning motivation and math. We fit a version of the bivariate Cholesky model that decomposes variation in an outcome Y into genetic and environmental factors that are shared with predictor X , and genetic and environmental factors that are unique of predictor X . This model is written as a system of two simultaneous equations

$$X_{t,p} = (s_x \cdot \text{SES}_p) + (a_x + a'_x \cdot \text{SES}_p) \cdot A_{x,t,p} + (c_x + c'_x \cdot \text{SES}_p) \cdot C_{x,p} + (e_x + e'_x \cdot \text{SES}_p) \cdot E_{x,t,p}, \quad (3a)$$

$$Y_{t,p} = (s_y \cdot \text{SES}_p) + (a_b + a'_b \cdot \text{SES}_p) \cdot A_{x,t,p} + (c_b + c'_b \cdot \text{SES}_p) \cdot C_{x,p} + (e_b + e'_b \cdot \text{SES}_p) \cdot E_{x,t,p} + (a_y + a'_y \cdot \text{SES}_p) \cdot A_{y,t,p} + (c_y + c'_y \cdot \text{SES}_p) \cdot C_{y,p} + (e_y + e'_y \cdot \text{SES}_p) \cdot E_{y,t,p}. \quad (3b)$$

Note that both equations allow for the main effect of SES and the interactions between SES and genetic and environmental variance components.

We hypothesized that the gene-by-SES interaction observed on mathematics could be accounted for by an increased relation between mathematics and genes for motivation; therefore, motivation was treated as the predictor X and math as the outcome Y . This model is depicted in Panel B of Fig. 1: math achievement is regressed onto the genetic and environmental components of motivation, and is additionally allowed to have genetic and environmental factors independent of learning motivation. The a_b' parameter was predicted to be significant, indicating an increased relation between math achievement and genetic differences in motivation at higher levels of SES. We further predicted that the a_y' parameter would be reduced relative to the a' parameter from the univariate model of math.

6.2. Results of bivariate analyses

Results of our bivariate analyses of the motivation \rightarrow achievement relation are presented in Table 3. For Step 1, in which all main effects and interaction parameters were estimated, the only interaction parameter that is significant is the a_b' parameter. This parameter is positive, indicating that genes for motivation are more strongly predictive of math at higher levels of SES. That the a_y' parameter is not statistically significant indicates that SES does not incrementally moderate genes for achievement that are unique of motivation. In other words, genes for motivation entirely mediate the gene-by-SES interaction previously documented for math. In Step 2, the model was refit with all interaction parameters that were not statistically significant in Step 1 removed. The main effects of genes on math were not statistically significant, indicating that all of the heritable variation in math is shared with motivation. The Step 3 model (removing the non-significant main effect of genes unique of motivation) fits as well as the full model fit in Step 1 ($\chi^2[12] = 18.10$) and therefore represents the preferred final model. This model, which also has the most preferred (lowest) AIC and BIC values of the three models, only includes significant parameters. Results from the final model indicated that (a) motivation is influenced by additive genes and the nonshared environment, but not the shared environment, (b) the link between motivation and math achievement occurs through a genetic pathway, (c) the genetic link between motivation and math achievement is positively moderated by SES, and (d) math achievement independent of motivation is influenced by the shared environment and the nonshared environment, but not genes nor the interaction between genes and SES. These results are illustrated in Fig. 3, which plots the variance in motivation

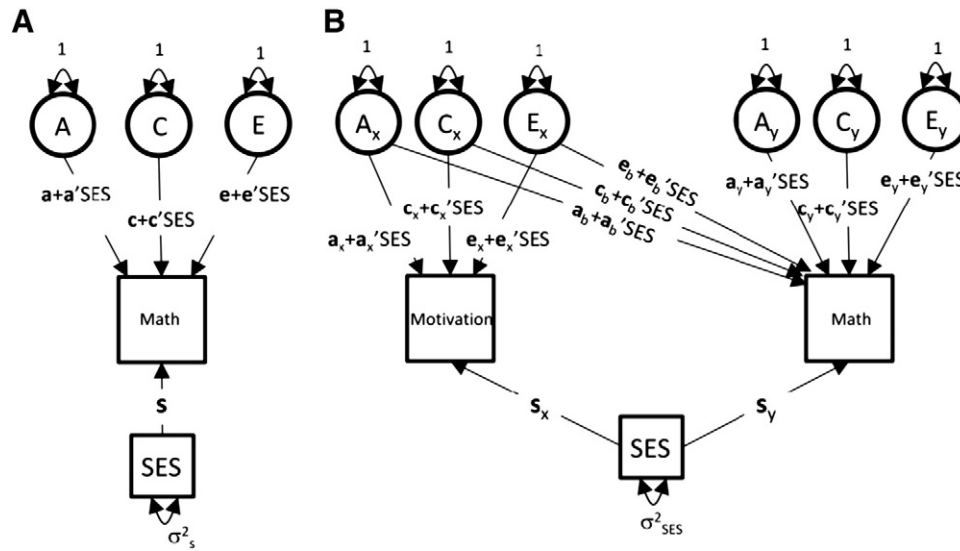

Fig. 1. Panel A: Path diagram for a univariate gene-by-SES interaction model for math achievement. For ease of presentation, only one twin from each pair is represented. Panel B: Path diagram for a bivariate gene-by-SES interaction model. This model represents a Cholesky decomposition of the variation in math achievement into genes and environments shared with, and unique of, motivation. For ease of presentation, only one twin from each pair is represented.

accounted for by genetic and environmental factors as functions of SES, the variance in achievement accounted for by the genetic and environmental components of motivation as functions of SES, and the variance in achievement independent of motivation accounted for by genetic and environmental factors as functions of SES. Only the genetic pathway from motivation to achievement varies with SES. There is no residual gene-by-SES interaction on Math after accounting for the effects of motivation. Thus, in the current sample, the previously documented gene-by-SES interaction on Math Achievement was fully mediated by genetic differences in learning motivation.

As a follow-up validity check, we refit the Cholesky model with motivation as the outcome *Y* and mathematics as the predictor *X*. Our rationale was that, if motivation were truly explaining an interaction on mathematics, rather than mathematics explaining an interaction on motivation, we should only expect the a_b' parameter to be significant in the motivation → mathematics model, but not the mathematics → motivation model. Results of these analyses are presented in Table 4. Again, we proceeded through a stepwise process in which nonsignificant interaction parameters were trimmed, the model was refit, nonsignificant main effects parameters were trimmed, and the model was refit again. The Step 3 model fit no worse than the full model from Step 1 ($\chi^2[10] = 10.22$), and also has the most preferred (lowest) AIC and BIC values. Key results from this model are illustrated in Fig. 4, which plots the variance in achievement accounted for by genetic and environmental factors as functions of SES, the variance in

motivation accounted for by the genetic and environmental components of achievement as functions of SES, and the variance in motivation independent of achievement accounted for by genetic and environmental factors as functions of SES. The math → motivation pathway was nearly entirely genetically mediated, although there was also some small but statistically significant mediation by the nonshared environment. In addition, SES positively moderated the genetic influences on math but did not moderate the math → motivation relation. These results are consistent with the hypothesis that it is the directional relation from motivation to math, rather than a reverse pathway from math achievement to increase motivation that is positively moderated by SES.

7. Discussion

The goal of the current project was to examine the link between 4-year old children's motivation to learn and their math achievement, the extent to which the motivation → achievement link operates through a genetic pathway, and whether the magnitude of the motivation → achievement link varies with socioeconomic status. These goals were motivated by previous findings that genes account for larger amounts of variation in academic achievement among children being raised in higher SES contexts than those being raised in lower-SES contexts. A number of results are of particular note. First, SES only accounted for a modest proportion of variance (9%) in motivation, but accounted for a considerably larger proportion of variance (28%) in

Table 1
Parameter estimates from univariate models of learning motivation.

Parameter	Step 1: full interaction model		Step 2: nonsignificant interactions trimmed		Step 3: nonsignificant main effects trimmed	
	Estimate	95% CI	Estimate	95% CI	Estimate	95% CI
<i>a</i>	.419	[.343, .495]	.429	[.380, .478]	.429	[.380, .478]
<i>a'</i>	-.021	[-.105, .063]				
<i>c</i>	.058	[-.193, .309]	.000	[-.284, .284]		
<i>c'</i>	-.083	[-.259, .093]				
<i>e</i>	.447	[.406, .488]	.442	[.403, .481]	.442	[.403, .481]
<i>e'</i>	-.018	[-.069, .033]				
<i>s</i>	.193	[.146, .240]	.195	[.150, .240]	.195	[.150, .240]
AIC	3986.733		3985.426		3983.426	
BIC	4031.836		4016.997		4010.487	

Parameters in bold are significant at $P < .05$.

Table 2
Parameter estimates from univariate models of math.

Parameter	Step 1: full interaction model		Step 2: nonsignificant interactions trimmed		Step 3: nonsignificant main effects trimmed	
	Estimate	95% CI	Estimate	95% CI	Estimate	95% CI
<i>a</i>	.303	[.207, .399]	.301	[.199, .403]	.301	[.199, .403]
<i>a'</i>	.149	[.067, .231]	.124	[.051, .197]	.124	[.051, .197]
<i>c</i>	.521	[.462, .580]	.526	[.467, .585]	.526	[.467, .585]
<i>c'</i>	−.055	[−.128, .018]				
<i>e</i>	.311	[.280, .342]	.313	[.280, .346]	.313	[.280, .346]
<i>e'</i>	.000	[−.029, .029]				
<i>s</i>	.423	[.360, .486]	.423	[.360, .486]	.423	[.360, .486]
AIC	3746.587		3745.094		3745.094	
BIC	3791.690		3781.177		3781.177	

Parameters in bold are significant at $P < .05$.

math achievement. Second, the amount of variance in motivation accounted for by genetic and environmental factors did not vary with SES, whereas the amount of variance in math achievement accounted for by genetic factors (but not environmental factors) did vary significantly with SES. At very low levels of SES, genes accounted for negligible variation in math scores, whereas at very high levels of SES, genes accounted for over 40% of the variation in math test scores. Third, the both the main effect of genes and the interaction effect of genes and SES on math achievement were completely mediated through genetic factors influencing motivation.

These results point to a substantial role of children in determining their own learning experiences, while at the same time pointing to a substantial role of socioeconomic context in facilitating or hindering this process. Although conventional conceptualizations of environmental effects have treated children as passive recipients of either high quality or low quality environmental inputs, the current results add to the accumulating body of evidence that environmental effects on child development operate by way of their interactions with child-driven processes. Under newer transactional theories of development (Dickens & Flynn, 2001; Scarr, 1992; Tucker-Drob & Harden, in press-a,b), heritable variation in cognition and achievement comes to be expressed through a process by which children select, evoke, and attend to experiences that are congruent with their genetically influenced traits. In high opportunity environments, as children grow, their levels of achievement become increasingly associated with their genotypes (i.e. increasingly heritable) because they select and attend to learning and educational experiences that are congruent with their

genotypes. In low opportunity environments, children are less able to match their learning experiences to their genotypes, and heritable variation in achievement remains low.

7.1. Limitations

A number of limitations of the current study are important to acknowledge. First, the models applied here make the standard assumptions of the classical twin-raised-together design, including no assortative mating, independence of variance components, and additive effects of genes and of environments. While these assumptions are likely to be violated in some instances, approaches that rely on different sets of assumptions (e.g. examinations of the similarity of adopted twins separated at birth, and examinations the similarity of unrelated adopted siblings) have generally produced heritability and environmental estimates of cognition similar in magnitude to those found using twins raised together in the same family (Bouchard & McGue, 1981). Moreover, Loehlin, Harden, and Turkheimer (2009); also see Tucker-Drob et al., 2011) have demonstrated that main effects of genes and environments are more affected by violations of standard assumptions than are interaction effects. Because the current study was primarily concerned with the gene-by-SES interaction effects, the major findings can be considered robust.

Second, children's motivation to learn was based on parental ratings. While parents are likely to be the best reporters of their young children's behavioral patterns, there is certainly some subjectivity to their ratings. To reduce any bias that might have resulted in this respect, it might have been preferable to analyze motivation ratings averaged from both a parent and a teacher. However, this was not feasible for the current sample as only a subset of children were attending formal daycare programs.

Third, the motivation measure used included items tapping a fairly diverse array of learning-related dispositions and behaviors. Some of the items tapped the extent to which the child pays attention to material. It may therefore be most appropriate to conceptualize the motivation measure used as an aggregate measure reflecting a number of learning-related dimensions that include interest in learning, and attention/distractability. Indeed, the items were originally selected by the ECLS team to tap a diverse set of "tendencies, behaviors, and skills that support a positive attitude about learning" (Najarian et al., 2010, p. 153). While this is consistent with our interest in a broad set of non-cognitive traits that relate to learning, other researchers may use the term motivation to refer to a more narrow trait than was measured in the current study. It is important for the reader to be aware that the current study conceptualized and operationalized motivation quite broadly.

A further limitation is that, although the ECLS-B twin subsample is relatively large by the standards of a twin study, it may have nevertheless been underpowered to detect more fine-grain gene-by-environment interactions. For instance, in the bivariate model with

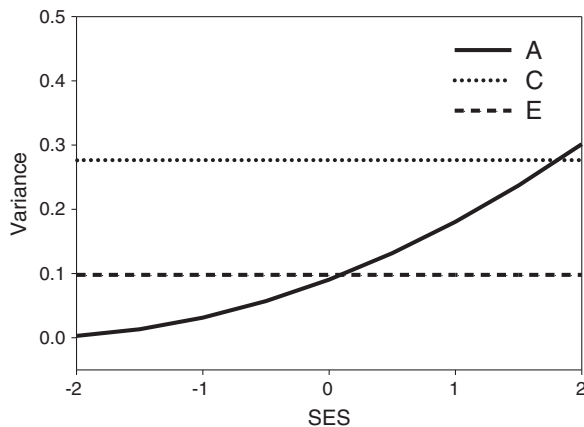

Fig. 2. Amounts of variance in early math skills accounted for by genes (A), the shared environment (C), and the nonshared environment (E), as functions of SES. Based on parameters reported in the last columns (Step 3) of Table 2. Note that the Y axis represents unstandardized variance.

Table 3
Parameter estimates from bivariate motivation → achievement models.

Parameter	Step 1: full interaction model		Step 2: nonsignificant interactions trimmed		Step 3: nonsignificant main effects trimmed	
	Estimate	95% CI	Estimate	95% CI	Estimate	95% CI
<i>Motivation</i>						
α_x	.421	[.358, .484]	.349	[.194, .504]	.414	[.365, .463]
α_x'	-.036	[-.105, .033]				
c_x	.039	[-.096, .174]	.188	[-.016, .392]		
c_x'	-.085	[-.248, .078]				
e_x	.447	[.408, .486]	.471	[.424, .518]	.456	[.419, .493]
e_x'	-.008	[-.057, .041]				
<i>Motivation → Math</i>						
a_b	.192	[.055, .329]	.299	[.168, .430]	.291	[.234, .348]
a_b'	.135	[.012, .258]	.119	[.050, .188]	.110	[.051, .169]
c_b	.434	[-.544, 1.412]	.007	[-.248, .262]		
c_b'	-.054	[-.185, .077]				
e_b	.047	[-.004, .098]	.024	[-.025, .073]		
e_b'	-.031	[-.086, .024]				
<i>Math.Motivation</i>						
a_y	.221	[.066, .376]	.084	[-.488, .656]		
a_y'	.095	[-.056, .246]				
c_y	.296	[-1.139, 1.731]	.527	[.466, .588]	.543	[.500, .586]
c_y'	-.024	[-.220, .172]				
e_y	.308	[.277, .339]	.312	[.279, .345]	.319	[.292, .346]
e_y'	.000	[-.031, .031]				
s_x	.194	[.147, .241]	.197	[.152, .242]	.196	[.151, .241]
s_y	.424	[.361, .487]	.424	[.361, .487]	.426	[.363, .489]
AIC	5952.295		5952.212		5946.392	
BIC	6060.541		6024.376		6000.515	

Parameters in bold are significant at $P < .05$. Math.Motivation refers to the variance in Math that is independent of Motivation.

motivation accounted for, the gene-by-SES interaction on math scores was not significant, indicating full mediation of the interaction, but it is possible that with a larger sample size this residual interaction would have remained significant, indicating only partial mediation of the interaction. Related to this limitation, is the fact that multiple interactions were tested in each model. While previous research and theory lead us to predict that genetic influences on achievement would be positively moderated by SES, we also tested the extent to which shared environmental and nonshared environmental influences on both approach to learning and achievement were moderated by SES. This inflated our potential for Type I error. Importantly, the gene-by-SES interaction on Mathematics achievement (the a' parameter in Table 2) was significant at $p = .0004$ (95% CI = .067–.231), which increases our confidence in the authenticity of the interaction.

7.2. Future directions

The current results among four year olds parallel recent finding that intellectual interest mediates the gene-by-SES interaction on achievement

among 17-year olds (Tucker-Drob & Harden, in press-a). In both the current study and our previous study, it was the genetic link between noncognitive traits and achievement that was more pronounced among higher SES students. Together, these results suggest that, throughout much of development, SES may enhance academic achievement by allowing greater conversion of genetically-based non-cognitive dispositions into achievement. Future work will be useful for examining the extent to which similar interactions documented at different periods of development represent the same versus distinguishable phenomena. Longitudinal data spanning early childhood to late adolescence may be particularly useful in this regard. Previous research has documented consistent cross-lagged longitudinal associations between non-cognitive dispositions and later academic achievement (Marsh & Craven, 2006; Marsh, Trautwein, Lüdtke, Köller, & Baumert, 2005), with some evidence that these associations are genetically mediated (Grevén, Harlaar, Kovas, Chamorro-Premuzic, & Plomin, 2009). One interesting and important future direction will be to examine whether these cross-lagged associations differ in their strength for children living in differing ranges of socioeconomic context, as might be

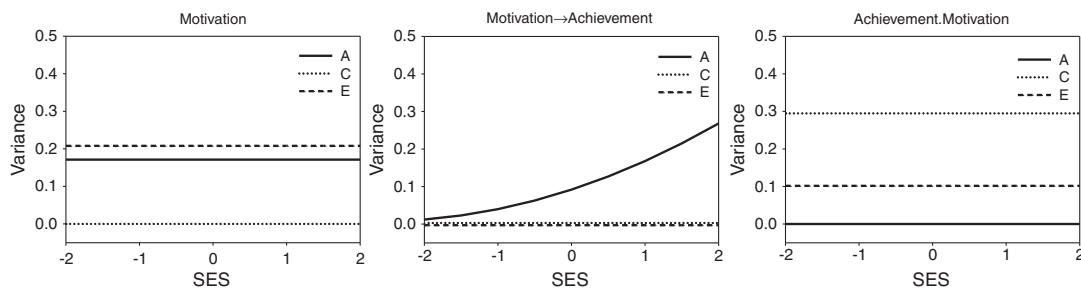

Fig. 3. Genetic and environmental components of motivation the regression of academic achievement on motivation (Motivation → Achievement), and the variance in academic achievement that is unique of motivation (Achievement.Motivation), as functions of SES. Based on parameters reported in the last columns (Step 3) of Table 3. Note that the Y axes represent unstandardized variance.

Table 4
Parameter estimates from bivariate achievement → motivation models.

Parameter	Step 1: full interaction model		Step 2: nonsignificant interactions trimmed		Step 3: nonsignificant main effects trimmed	
	Estimate	95% CI	Estimate	95% CI	Estimate	95% CI
<i>Math</i>						
a_x	.286	[.186, .386]	.300	[.202, .398]	.329	[.253, .405]
a_x'	.163	[.083, .243]	.131	[.058, .204]	.117	[.054, .180]
c_x	.529	[.470, .588]	.529	[.470, .588]	.512	[.459, .565]
c_x'	-.057	[-.130, .016]				
e_x	.314	[.283, .345]	.313	[.282, .344]	.309	[.280, .338]
e_x'	-.003	[-.032, .026]				
<i>Math→Motivation</i>						
a_b	.305	[.111, .499]	.219	[.080, .358]	.277	[.179, .375]
a_b'	-.061	[-.186, .064]				
c_b	.029	[-.053, .111]	.051	[-.027, .129]		
c_b'	-.041	[-.137, .055]				
e_b	.065	[-.004, .134]	.079	[.012, .146]	.062	[.001, .123]
e_b'	-.021	[-.084, .042]				
<i>Motivation. Math</i>						
a_y	.294	[.094, .494]	.364	[.278, .450]	.322	[.228, .416]
a_y'	.022	[-.117, .161]				
c_y	.024	[-.419, .467]	.00	[-.306, .306]		
c_y'	-.032	[-.522, .458]				
e_y	.440	[.399, .481]	.436	[.399, .473]	.441	[.404, .478]
e_y'	-.014	[-.065, .037]				
s_x	.193	[.148, .238]	.196	[.151, .241]	.196	[.151, .241]
s_y	.423	[.360, .486]	.426	[.363, .489]	.425	[.364, .486]
AIC	5952.315		5944.999		5942.537	
BIC	6060.561		6017.163		6005.680	

Parameters in bold are significant at $P < .05$. Motivation.Math refers to the variance in Motivation that is independent of Math.

predicted by transactional models. A second important future direction will be to move beyond an omnibus measure of SES, towards identifying specific environmental contexts – including characteristics of families, schools, and neighborhoods – that provide opportunities for conversion of noncognitive traits into achievement. Different aspects of the environment will likely vary in their importance with different periods of development. For instance, home environments are likely to be particularly important in early childhood, but may diminish in importance as children begin spending the majority of their time in schools and with peers (Tucker-Drob, *in press*). Finally, a third future direction will be to begin to distinguish between different forms of non-cognitive traits that interact with SES. A diverse array of non-cognitive traits have been linked with achievement (e.g. motivation, interest, self concept, achievement orientation, openness to experience; von Stumm, Chamorro-Premuzic, & Ackerman, 2011), and it is possible that some traits may interact with socioeconomic opportunity more strongly than others, and that these patterns may differ at different periods of development.

8. Conclusion

There is now substantial evidence that that genetic influences on cognition and achievement are maximized in higher quality environments, and that these gene-by-environment interactions begin very early in life (Rhemtulla & Tucker-Drob, *submitted for publication*; Rowe et al., 1999; Tucker-Drob et al., 2011; Turkheimer et al., 2003). The current study was motivated by the hypothesis that one mechanism for these gene-by-environment interactions is a dynamic process in which high quality environments enable children to expose themselves more selectively, and attend more acutely, to learning experiences that are consistent with their genetically-influenced motivations to learn. Results from a nationally-representative sample of more than 650 American four-year-old twin pairs were consistent with this hypothesis. We found that genetic differences in learning motivation were more strongly predictive of math achievement among children in higher SES homes, and that this interaction fully mediated a previously identified gene-by-socioeconomic status interaction on math achievement.

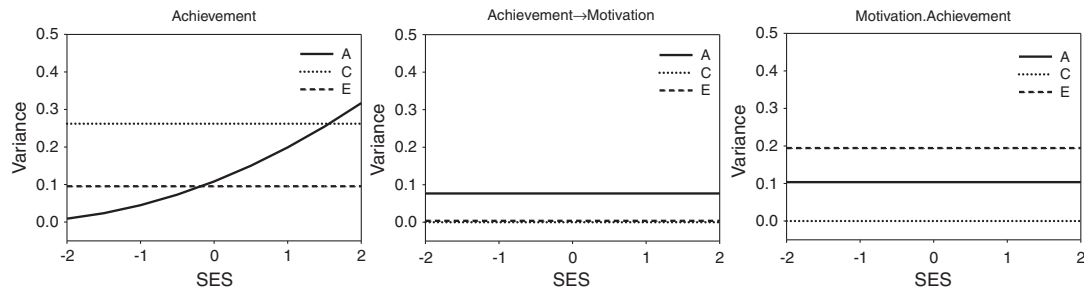

Fig. 4. Genetic and environmental components of math achievement, the regression of motivation on math (Motivation → Achievement), and the variance in motivation that is unique of math achievement (Motivation.Achievement), as functions of SES. Based on parameters reported in the last columns (Step 3) of Table 4. Note that the Y axes represent unstandardized variance.

Acknowledgements

Preparation of this article was supported by NIH grant R21 HD069772. The Population Research Center at the University of Texas at Austin is supported by NIH center grant R24 HD042849. The analyses presented here use data from the ECLS-B data file, which was provided by the U.S. Department of Education National Center for Education Statistics.

References

- Bouchard, T. J., & McGue, M. (1981). Familial studies of intelligence: A review. *Science*, 212, 1055–1059.
- Bouchard, T. J., Jr., & McGue, M. (2003). Genetic and environmental influences on human psychological differences. *Journal of Neurobiology*, 54, 4–45.
- Bradley, R. H., Corwyn, R. F., McAdoo, H., & Coll, C. (2001). The home environments of children in the United States: Part I. Variations by age, ethnicity, and poverty status. *Child Development*, 72, 1844–1867.
- Bronfenbrenner, U., & Ceci, S. J. (1994). Nature-nurture reconceptualized in developmental perspective: A bioecological model. *Psychological Review*, 101, 568–586.
- Capron, C., & Duyme, M. (1989). Assessment of effects of socio-economic status on IQ in a full cross-fostering study. *Nature*, 340, 552–554.
- Caspi, A., Roberts, B. W., & Shiner, R. L. (2005). Personality development: stability and change. *Annual Review of Psychology*, 56, 453–484.
- Cattell, R. B. (1987). *Intelligence: its structure, growth, and action*. Amsterdam: North-Holland.
- De Wolff, M. S., & van Ijzendoorn, M. H. (1997). Sensitivity and attachment: a meta-analysis on parental antecedents of infant attachment. *Child Development*, 68, 571–591.
- Dickens, W. T., & Flynn, J. R. (2001). Heritability estimates versus large environmental effects: The IQ paradox resolved. *Psychological Review*, 108, 346–369.
- Dickens, W. T., Turkheimer, E., & Beam, C. (2011). The social dynamics of the expression of genes for cognitive ability. In K. S. Kendler, S. Jaffee, & D. Romer (Eds.), *The Dynamic Genome and Mental Health: The Role of Genes and Environments in Youth Development*. New York: Oxford University Press.
- Duncan, G. J., et al. (2007). School readiness and later achievement. *Developmental Psychology*, 43, 1428–1446.
- Garrett, P., Ng'andu, N., & Ferron, J. (1994). Poverty experiences of young children and the quality of their home environments. *Child Development*, 65, 331–345.
- Gresham, F. M., & Elliott, S. N. (1990). *The Social Skills Rating System*. Circle Pines, MN: American Guidance Service.
- Greven, C., Harlaar, N., Kovas, Yulia, Chamorro-Premuzic, Tomas, & Plomin, R. (2009). more than just IQ: School achievement is predicted by self-perceived abilities-but for genetic rather than environmental reasons. *Psychological Science*, 20, 753–762.
- Harden, K. P., Turkheimer, E., & Loehlin, J. C. (2007). Genotype by environment interaction in adolescents' cognitive aptitude. *Behavior Genetics*, 37, 273–283.
- Heckman, J. J. (2006). Skill formation and the economics of investing in disadvantaged children. *Science*, 312, 1900–1902.
- Kagan, S. L., Moore, E., & Bredekamp, S. (1995). *Reconsidering Children's Early Development and Learning: Toward Common Views and Vocabulary*. : National Education Goals Panel.
- Loehlin, J. C., Harden, K. P., & Turkheimer, E. (2009). The effects of assumptions about parental assortative mating and genotype-income correlation on estimates of genotype-environment interaction in the National Merit Twin Study. *Behavior Genetics*, 39, 165–169.
- Magnuson, K. A., Meyers, M. K., Ruhm, C. J., & Waldfogel, J. (2004). Inequality in preschool education and school readiness. *American Educational Research Journal*, 41, 115–157.
- Marsh, H. W., & Craven, R. G. (2006). Reciprocal effects of self-concept and performance from a multidimensional perspective: beyond seductive pleasure and unidimensional perspectives. *Perspectives on Psychological Science*, 1, 133–163.
- Marsh, H. W., Trautwein, U., Lüdtke, O., Köller, O., & Baumert, J. (2005). Academic self-concept, interest, grades and standardized test scores: reciprocal effects models of causal ordering. *Child Development*, 76, 297–416.
- Muthén, B. O., & Muthén, L. (1998–2010). *MPlus User's Guide* (Sixth edition). Los Angeles, CA: Muthén and Muthén.
- Najarian, M., Snow, K., Lennon, J., & Kinsey, S. (2010). *Early Childhood Longitudinal Study, Birth Cohort (ECLS-B), Preschool-Kindergarten 2007 Psychometric Report (NCES 2010-009)*. Washington, DC: National Center for Education Statistics, Institute of Education Sciences, U.S. Department of Education.
- Nelson, C. A., Zeanah, C. H., Fox, N. A., Marshall, P. J., Smyke, A. T., & Guthrie, D. (2007). Cognitive recovery in socially deprived young children: the Bucharest Early Intervention Project. *Science*, 318, 1937–1940.
- Purcell, S. (2002). Variance components models for gene-environment interaction in twin analysis. *Twin Research*, 5, 554–571.
- Rhemtulla, M., & Tucker-Drob, E. M. (submitted for publication). Gene-by-socioeconomic status interaction on school readiness.
- Rowe, D. C., Jacobson, K. C., & Van den Oord, E. J. C. G. (1999). Genetic and environmental influences on vocabulary IQ: parental education level as moderator. *Child Development*, 70, 1151–1162.
- Scarr, S. (1992). Developmental theories for the 1990's: development and individual differences. *Child Development*, 63, 1–19.
- Scarr, S., & McCartney, K. (1983). How people make their own environments: a theory of genotype → environment effects. *Child Development*, 54, 424–435.
- Sirin, S. R. (2005). Socioeconomic status and academic achievement: a meta-analytic review of research. *Review of Educational Research*, 75, 417–453.
- Taylor, J., Roehrig, A. D., Hensler, B. S., Connor, C. M., & Schatschneider, C. (2010). Teacher quality moderates the genetic effects on early reading. *Science*, 328, 512–514.
- Taylor, J., & Schatschneider, C. (2010). Genetic influence on literacy constructs in kindergarten and first grade: evidence from a diverse twin sample. *Behavior Genetics*, 40, 591–602.
- Tucker-Drob, E. M. (in press). Preschools reduce early academic achievement gaps: A longitudinal twin approach. *Psychological Science*.
- Tucker-Drob, E. M., & Harden, K. P. (in press-a). Intellectual interest mediates gene-by-SES interaction on adolescent academic achievement. *Child Development*.
- Tucker-Drob, E. M., & Harden, K. P. (in press-b). Early childhood cognitive development and parental cognitive stimulation: Evidence for reciprocal gene-environment transactions. *Developmental Science*.
- Tucker-Drob, E. M., Rhemtulla, M., Harden, K. P., Turkheimer, E., & Fask, D. (2011). Emergence of a gene-by-socioeconomic status interaction in infant mental ability from 10 months to 2 years. *Psychological Science*, 22, 125–133.
- Turkheimer, E., Haley, A., Waldron, M., D'Onofrio, B., & Gottesman, I. (2003). Socioeconomic status modifies heritability of IQ in young children. *Psychological Science*, 14, 623–628.
- von Stumm, S., Chamorro-Premuzic, T., & Ackerman, P. L. (2011). Re-visiting intelligence-personality associations: vindicating intellectual investment. In T. Chamorro-Premuzic, S. von Stumm, & A. Furnham (Eds.), *Handbook of Individual Differences*. Chichester, UK: Wiley-Blackwell.
- White, K. R. (1982). The relation between socioeconomic status and academic achievement. *Psychological Bulletin*, 91, 461–481.